



Wiiibox.com

Wiiibox[®] DLP JEW

DLP 3D Printer for Industrial Applications



Wiiibox DLP JEW is light-curing 3D printer for industrial smart manufacturing, which can quickly form, manufacture in small batches, and form with complex structures.



Custom LED Light



Low maintenance costs



Two Printing Mode



Convenient Operation

✉ sales@wiiibox.net

☎ TEL: 0086-25-84109995

🏢 Nanjing Wiiibox 3D Technology Co., Ltd.

📍 14F, Building 4, No. 12 Mozhou East Road, Nanjing, China, 211111

🌐 Website: www.wiiibox.com

size

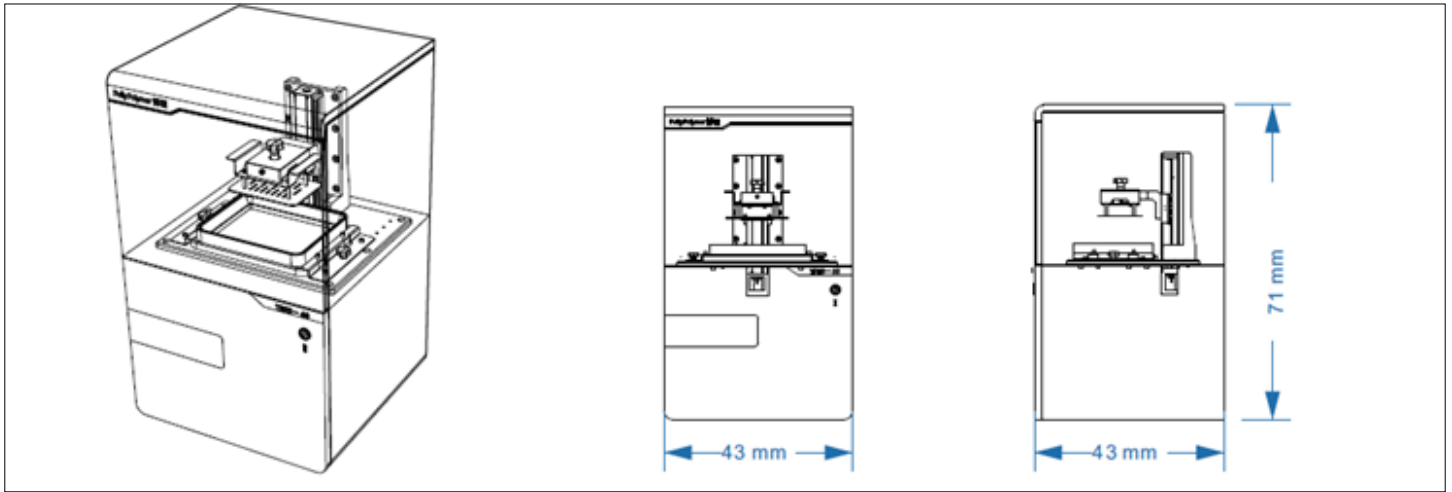

Application



Parameter & Advantages

| | | |
|---------------------|--------------------------------|--|
| Printing Size | 128mm x 80mm x 160mm | Mechanized production, saving labor |
| Resolution Accuracy | 100 um | Large forming area and high production efficiency |
| Layer Thickness | 20-100 um | Good controllability and high precision. |
| Printing Speed | 5-15s/layer | Self-developed consumables with high compatibility and low cost. |
| Equipment Size | 43cmx43cmx71cm | Strong technical support, mature after-sales service |
| Equipment Weight | 45 kg | UV LED light machine system with a life of up to 50,000 hours |
| Molding Technology | Digital Light Processing (DLP) | Light intensity calibration compensation technology |
| Printing software | Structure | Support for new UI design, better customer experience |
| File format | STL, SLC | Perfect appearance, portable and practical |
| System support | Windows | High surface smoothness |